



emacoustics

# CS18

## ADVANCED PASSIVE CARDIOID SUBWOOFER

### PRELIMINARY TECHNICAL DATA SHEET

**The CS Subwoofers from EM Acoustics add superb cardioid low frequency control to the product ecosystem. These products are not only compact, beautifully voiced and abundantly powerful but also utilise advanced passive crossover technology for unmatched simplicity and flexibility in use. Critically, subwoofers in the series are fully passive and require only a single amplifier channel in operation. Two size options are available, in variants for install as well as touring environments.**

#### FEATURES AND BENEFITS

- Medium format cardioid subwoofer
- 18"/15" neodymium high-excursion LF drive units
- Tour-grade castors included
- Protective floor runners and matching stacking recesses
- Quick-release flying system
- Install-friendly M10 threaded rigging points
- Impact and weather resistant black or white finish as standard
- RAL colour and weather protection options

#### APPLICATIONS

- Medium scale live music reinforcement
- Theatre
- Houses of worship
- Conference, corporate and audio-visual
- Theme parks



Designed for any application that requires precise control of low frequency directionality, the CS18 is the larger of the two CS Series subwoofers. The compact CS18 enclosure offers a level of SPL and rear rejection that defies its physical size and is built to an exceedingly high standard, giving extended operating life in even the most demanding environments.

The CS18 houses a front-firing 4" voice coil 18" (457mm) LF drive unit, and a rear-firing 3" voice coil 15" (381mm) LF drive unit. Both neodymium drive units are designed for maximum linearity even at high excursion, ensuring performance is consistent throughout the entire operating envelope. Each drive unit is housed within its own acoustic chamber, which are rigidly braced and make use of optimally tuned bass reflex porting.

The CS18 generates a highly consistent cardioid pattern which maximises output whilst significantly reducing the radiation to the sides and rear of the enclosure. To create this pattern, both drive units are linked via a highly advanced internal passive crossover. The R&D parameters of the CS subwoofers called for passive

crossovers which equalled or bettered the performance available from conventional dual-channel actively processed designs. This has been achieved, meaning the CS18 requires only one amplifier channel yet produces in excess of 20dB of rejection to the rear. Reducing the low frequency energy radiating to the rear helps to keep stages and performance environments sonically cleaner, resulting in a more accurate overall system response and radically improved sonic presentation.

The robust CS18 enclosure houses four flush bar handles, protective skids on its underside and mating recesses in the top face. Both front and rear drive units are protected by hex-punched grilles, manufactured from stainless steel for enhanced lifespan. Both grilles are backed by an acoustically transparent mesh to complete the discreet appearance. An M20 threaded pole adapter, 20 M10 installation flying points and two keyhole quick release flyplates complete the hardware compliment. The flyplates allow quick and easy mating with flying accessories, and additional subwoofers can be joined into a column using the M10 points and linking plates. A pair of male Neutrik speakON™ NLT4 connectors are fitted as standard.

Additionally, the CS18 can be supplied with a female/male combination and other outdoor or installation connector variants. Usefully, the passive design makes available a second pair of contacts on the standard NL4 connectors, allowing subwoofers and fullrange loudspeakers to be driven on a single 4-core cable.

The CS18 enclosure is constructed from multi-laminate premium birch plywood and is finished in an impact and weather-resistant textured polyurethane finish. Black and white are available as standard, and RAL colour matching, as well as enhanced weather protection installation variants are also available.

The CS18 requires a single amplifier channel with DSP for active high/low pass filters and limiters. For peak performance and system matching EM Acoustics' range of Advanced System Amplifiers are recommended. However, CS series subwoofers are essentially amplifier agnostic, so it is possible to use other DSP-enabled amplifiers, or conventional amplifiers with external DSP. Suitable DSP settings are provided on the EM Acoustics website. Amplifiers driving CS18s should be capable of delivering 1000-1600W RMS into a 6-ohm load.

The CS18 is an ideal companion for medium to large fullrange products within the EM Acoustics range – such as the Reference Series R8, R10 or R12, EMS-156/159 or the HALO-B line array system.

## TECHNICAL SPECIFICATIONS

ENCLOSURE TYPE:	Reflex-loaded passive cardioid subwoofer
DIMENSIONS (HxWxD):	(HxWxD) 604 (23.8) x 634 (25) x 840 (33.1) mm/(ins)
NET/SHIPPING WEIGHT:	75.4/78.4kg (165.9/172.5lbs)
FREQUENCY RESPONSE <sup>1</sup> :	35Hz – 100Hz ±3dB
SENSITIVITY <sup>2</sup> :	98dB
DISPERSION <sup>3</sup> :	Cardioid
DRIVE UNITS:	Front: 4" (102mm) voice coil, 18" (457mm) neodymium drive unit Rear: 3" (76mm) voice coil, 15" (381mm) neodymium drive unit
LOUDSPEAKERS PER AMPLIFIER (maximum for full loudspeaker SPL):	DQ6: 1 per channel, DQ10: 1 per channel, DQ20: 2 per channel Di06: not recommended, Di10: not recommended, Di20: 1 per channel
LOUDSPEAKERS PER AMPLIFIER (recommended absolute maximum) <sup>4</sup> :	DQ6: 1 per channel, DQ10: 2 per channel, DQ20: 2 per channel Di06: not recommended, Di10: 1 per channel, Di20: 1 per channel
POWER HANDLING:	800W RMS, 1600W program
MAXIMUM SPL <sup>5</sup> :	131dB continuous, 137dB peak
NOMINAL IMPEDANCE:	6 ohms
CROSSOVER:	Internal, advanced passive cardioid
CONNECTORS:	2 x Neutrik® speakON™ NLT4MP
ENCLOSURE:	15mm (5/8") & 18mm (3/4") multi-laminate Birch plywood – rebated, screwed and glued. Finished in impact and weather-resistant textured polyurethane 8 x flush bar handles, touring runners & mating recesses, tour-grade castors Quick-release flying system, M20 threaded polemount, 20 x M10 threaded fittings
RIGGING & HARDWARE:	Hex punched stainless steel backed with acoustically transparent mesh
GRILLES:	Colours/Connectors/Enhanced Weather Protection
OPTIONS:	FB-CS18 flybar FP-CS flyplate set TC-CS18 padded transit cover
ACCESSORIES:	

### NOTES ON MEASUREMENT CONDITIONS:

<sup>1</sup>Measured on-axis at 2m in an anechoic environment and referenced to 1m. <sup>2</sup>Measured in half space at 2m with 4W sine wave input and referenced to 1m. <sup>3</sup>Nominal dispersion, measured in an anechoic environment and averaged over stated bandwidth. <sup>4</sup>These loudspeaker quantities are the recommended maximum, and will not drive the loudspeaker to full output. <sup>5</sup>Calculated and verified by subjective listening test of familiar program material.



## ENCLOSURE OPTIONS

CS18 enclosures are available as standard in black or white textured polyurethane finish. Custom RAL colours can be supplied on request; extended lead times and set up costs apply. CS18 enclosures can also be supplied as an outdoor version (OD), with enhanced weather protection features, many bespoke to the customer's request. Please contact your local EM Acoustics representative for details.

## ENGINEERING DRAWING

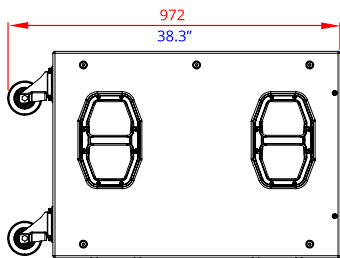
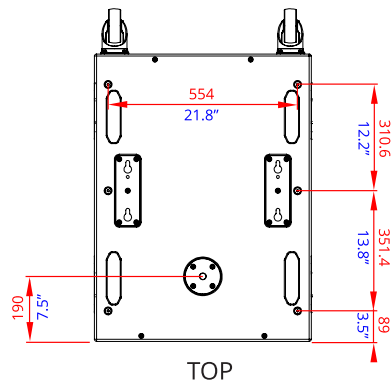

LEFT

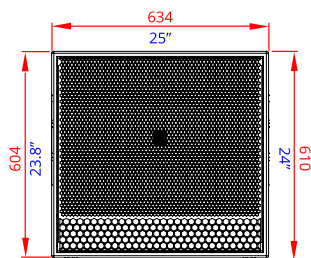

FRONT

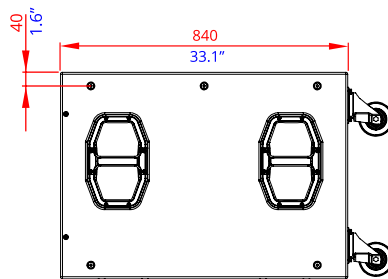

RIGHT

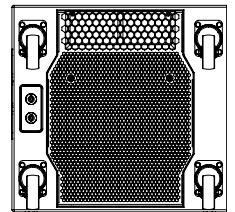

REAR

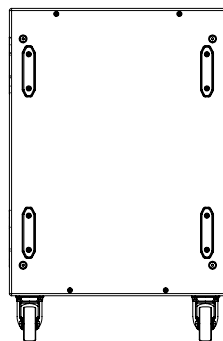

BOTTOM